



AN ENERGY-EFFICIENT HOME AUTOMATION SYSTEM USING INTERNET OF THINGS

^{#1}VODNALA MAMATHA, *Assistant Professor,*

^{#2}ARKUTI SRAVANI, *B.Tech Student,*

^{#3}BATHULA VAMSHI KRISHNA, *B.Tech Student,*

^{#4}DURGAM INDHU, *B.Tech Student,*

^{#5}RANGU HARSHA VARDHAN, *B.Tech Student,*

Department of Electronics and Communication Engineering,

TRINITY COLLEGE OF ENGINEERING AND TECHNOLOGY, PEDDAPALLY, TG.

ABSTRACT: An IoT-based smart home control system that saves energy and makes life easier for users is the focus of this research. Using cloud computing, smart sensors, and actuators, the technology monitors and controls home appliances in real-time. The Internet of Things paves the way for automated systems that respond to changes in the surrounding environment and human actions in order to lower power usage. In order to improve efficiency, machine learning algorithms try to forecast how much energy will be used in the future. With the ability to access it remotely through mobile apps, it gives users independence and peace of mind. Smart meters enable energy conservation by providing users with timely feedback. For our own existence, we need to switch to renewable energy sources. The home's automatic lighting, climate control, and security systems all contribute to its lower energy consumption. The research looks at how affordable, scalable, and compatible IoT devices are. Preventing unauthorized access by individuals is the goal of cybersecurity measures. By adapting to different living conditions, the suggested method improves energy efficiency. Energy conservation and an enhanced user experience are highlighted in case studies. Improving optimization through AI improvements is the focus of future research. Sustainable smart home solutions are made possible by the Internet of Things, according to the results.

Keywords: Smart Home, IoT, Energy Efficiency, Home Automation, Machine Learning, Smart Sensors, Renewable Energy, Cyber security, Smart Meters, Remote Access.

1. INTRODUCTION

The expansion of the Internet of Things is defined by its rapidity. Because of this, home technology has come a long way, paving the way for smart energy solutions that are better for the environment and more efficient. Through the use of IoT technology, smart home management systems monitor, manage, and optimize a household's energy consumption. In response to the growing need for smart

homes and energy efficiency, these systems automate appliance maintenance, reducing wasteful energy consumption and increasing user comfort.

Internet of Things (IoT) home automation systems may collect data on energy consumption in real-time with the help of smart sensors, actuators, and cloud computing. Depending on the current occupancy and outside conditions, these systems modify the building's lighting,





temperature, and ventilation. Accurately predicting energy use and automating operations are two ways in which machine learning algorithms increase efficiency. Homeowners can gain more independence and control over their energy consumption by using apps on their smart phones to regulate and monitor their appliances from anywhere.

Internet of Things (IoT) smart home gadgets use renewable energy sources, such as solar electricity, to reduce their impact on conventional power networks. This is one of the main benefits. Smart meters enable people to make informed decisions about their energy consumption by providing real-time data on electricity usage. Intelligent homes are convenient, secure, and efficient in terms of energy use. The whole house is now more secure thanks to AI-generated alarms, automated locks, and monitoring systems.

Notwithstanding the numerous benefits it offers, it is necessary to overcome the difficulties associated with installation, security risks, and compatibility before it can be used by a large number of people. Home automation systems that are both intelligent and energy efficient can benefit from stronger encryption, simplified communication protocols, and cheaper technology. Renewable energy sources, enhanced security measures, and AI-driven predictive analytics will define home automation as the Internet of Things (IoT) develops. Buildings will consequently become more eco-conscious and technologically sophisticated.

2. LITERATURE SURVEY

Pathare & Sethi (2024) – The potential of the IoT to improve the administration of

renewable energy sources in smart homes is explored in this research. One way to improve the efficiency of power transmission is through net metering. Finding ways to automate tasks in order to save energy is the main goal of the research. The topic of smart grid integration is being debated. Sustainable energy sources are advocated for in the paper.

Pawar et al. (2024) - Smart home automation technologies fueled by solar energy are examined in this article. It demonstrates the changes made to household systems in order to reduce energy use. Possible uses of AI with the Internet of Things are discussed in this article. Possible setbacks are considered, and our next steps are deliberated. Lifestyle choices that are good for the environment are strongly encouraged.

Oseiwe & Ajadalu (2024) - The best way for smart houses to use energy was determined by this research's use of reinforcement learning. The essay delves at the IoT's capacity to reduce energy consumption. Adaptive control techniques are a part of the research. Thanks to machine learning, real-time adjustments to energy consumption are now feasible. A considerable decrease in energy expenditures is shown by the results.

Abbas et al. (2024) - An automated system for controlling home energy usage is shown in this research. It is critically important to regulate smart devices. Improved oversight and productivity are outcomes of implementing IoT. Financial savings and environmental sustainability are the top priorities of the poll. The steps to improve smart energy systems are now being discussed.



Garg et al. (2023) - Building automation modulates energy consumption and improves occupant comfort, as this essay will explore. There are a number of ways to make sure that green building practices are followed. Safety, illumination, and climate control are the main points of the research. We take a look at ways to make energy use more efficient. Some ideas exist for the future development of environmentally friendly robots.

Kalogridis et al. (2021) - The major focus of this piece is on worries about the security of personal information that might be posed by smart meters. The issue of appliance load profiles that cannot be tracked is resolved. Various techniques for encrypting data are examined. The main goal of the research is to put an end to the illegal practice of tracking people's energy usage. Smart grids may put people's personal data at risk, as this article explains.

Sou et al. (2021) - The scheduling of smart home appliances is done in this research using mixed-integer linear programming. Saving money and making the most efficient use of energy are the main points. Dynamic load balancing is the project's main goal. AI-powered scheduling maximizes efficiency in power usage. Intelligent home systems benefit from this method's improved control.

Lee et al. (2021) - The use of cloud computing in smart home management is explained in this research. There is a system in place for people to trade resources inside the community. The integration of IoT facilitates real-time tracking of objects. Primarily, the inquiry is focused on safety and energy

efficiency. Smart towns are often praised for their practicality.

Kim et al. (2020) - The research examines home display systems that monitor energy consumption. People can better understand their energy usage with its help. More prudent energy consumption is made possible by real-time feedback. Analytics on data and the Internet of Things make it easier for more people to get involved. According to the research, using renewable energy sources is beneficial.

Son et al. (2020) - A home energy management system that is wired is the subject of this research. It has smart features that help in energy saving. Energy costs are decreased by the system. You can optimize your energy use with real-time tracking. We take a look at real-world smart home apps and how they work.

Kushiro et al. (2020) - Building an integrated home gateway controller is the goal of this project. It makes it easier for homeowners to install energy management systems. On the demand side, energy management is made easier by the technology. Tracking through the Internet of Things boosts efficiency. There is a lot of debate over major changes to home electronics.

Hernandez et al. (2020) - The goal of this research is to improve home lighting through the use of neural networks. Energy efficiency is improved by regulations that use AI. In particular, methods of variable illumination are investigated in the research. Intelligent gadgets change the light levels on their own. There was a considerable increase in energy efficiency, according to the findings.

Han et al. (2020) - Certain home appliances' energy usage is the subject of



this research. An energy management system is something that eco-conscious people should install in their homes. Optimization is made much easier with real-time tracking. The results show that AI can improve productivity in the workplace. Intelligent solutions that reduce energy use are given more priority.

Ramlee et al. (2020) - A home control system is the subject of this paper's discussion. With the help of IoT technologies, you may control your equipment from a distance. Research into cost-cutting technology is the focus of this research. Energy management and security are two essential parts. Applications for smart homes are investigated.

Shakeri et al. (2020) - Smart home energy management is demonstrated in this research. Upon request, we can improve our strategies. The reduction in energy consumption is a major benefit of AI-powered automation. The research examines methods for interfacing with the smart grid. People are fighting for the use of alternative energy.

Kumar & Kumar (2020) - The Internet of Things is the only focus of this research. This is a perfect example of how home electronics can make you more efficient. The monitoring of energy use in real-time is made much easier with IoT connectivity. Findings from the research suggest that AI can make power consumption monitoring easier. The possible future uses of innovative energy control technology have been the subject of much debate.

Alam et al. (2020) - The development of smart home technology is going to be tracked by this research. It brings together ideas from the present with those from the far future. The most recent developments

in AI, robotics, and the Internet of Things are reviewed. The difficulties of introducing smart home technologies are covered in this article. Various more lines of investigation into the matter are suggested in the report.

Khan & Khan (2020) - The possibilities of machine learning to strengthen cloud security are explored in this review. It delves into the ways in which AI can aid in the detection of dangers. Problems in hacking cloud systems are discussed in the article. Various methods for improving privacy are examined. The topic of smart homes and the IoT are covered in this meeting.

Pal et al. (2020) - The essay delves into the topic of elder care as it pertains to the Internet of Things. Smart homes made for the elderly are fascinating to many. Safety and well-being are improved with the help of AI-enhanced surveillance. Your vital signs can be tracked in real-time with the use of wearable technology. Decisions for independent living are supported by research.

Siano & De Marco (2020) - Energy markets in many regions have had conversations about distributed ledger technology. Emphasis is placed on the need of security and transparency. Practical uses of blockchain technology are the primary emphasis of the research. New avenues for investigation have been suggested.

Zhou et al. (2020) - The possibility for smart homes to control their own energy usage is explored in this article. Planning and organizing can be accomplished in a variety of ways. Productivity is enhanced through the use of AI-powered automation. The research looks at potential methods for



monitoring in real-time. Efficiency in energy consumption is a primary concern. Gungor et al. (2020) - Interaction between smart grids is the focus of this research. New rules that make power delegation easier are covered in it. Grid management is made easier with the Internet of Things (IoT). Problems caused by hacking are discussed in the article. Analyzed is the trajectory of smart grid technology going forward.

Li & Wen (2020) - Smart grid demand response management is the main focus of the research. The article delves into the topic of energy efficiency. Robots with the ability to think for themselves are still being developed by humans. The research finds a number of ways to cut costs. New suggestions for better ways to meet demand have surfaced.

Yan et al. (2020) - The interconnection of smart grids is the focus of this poll. We take a look at network-related concerns and needs. The possible applications of the IoT in power distribution are explored in this essay. Everyone is familiar with the many security threats and how to counter them. There have been suggestions that smart grid connections might soon be better.

3. PROPOSED SYSTEM

A central control unit can be reached by smart devices using Bluetooth, Zigbee, and Wi-Fi in the suggested system. Google Assistant, Amazon Alexa, and similar voice assistants make it easy to access and manage the system from any mobile device. In order to determine the most efficient use of energy, the system employs machine learning to examine historical data and make predictions.

Quick notification will be sent to the user in the event that their device exhibits any unusual behavior, such as an electrical malfunction, excessive or insufficient power consumption, or others. Intelligent machines may plan their operations in a way that uses the least amount of power, allowing them to keep running even when the power goes off. The efficiency, security, and eco-friendliness of smart homes are all improved by this predictive method.

Among the many advantages of the method is a reduction in carbon emissions and energy costs. Users can enhance environmental protection and reduce waste by utilizing energy more efficiently, facilitated by advanced automation. Smart door locks and remote monitoring are just two of the features that can enhance your sense of safety when you install a home security system. One way to make green energy more accessible is to install solar panels and other renewable energy sources. Using the IoT, this home automation system allows for smarter, more efficient, and longer-lasting energy management.

BENEFITS:

- **Energy Conservation** – Building lighting, temperature management, and appliance power consumption can all be optimized for energy conservation by the system in response to occupancy levels and outside weather conditions.
- **Cost Savings** – Homeowners can drastically cut their monthly power bills by reducing their energy consumption and making use of clever energy management and automatic scheduling.



- **Remote Monitoring & Control** – The ability to remotely monitor and control home appliances is becoming more common as people increasingly rely on voice assistants and mobile applications.
- **Enhanced Security** – Intelligent locks, surveillance cameras, and motion detectors are the building blocks of an intelligent home automation system. Remote access and real-time notifications are two features that greatly enhance home security.
- **Predictive Maintenance** – Anomalies in electrical current and unique energy patterns can be detected by the sensors that make up the Internet of Things (IoT). As a result, equipment is less likely to break down and repair expenses are lower.
- **Environmental Sustainability** – The system actively encourages eco-friendly lifestyle choices by reducing energy waste and making use of renewable energy sources like solar panels.
- **User Customization & Automation** – The use of programming their appliances to conform to predetermined schedules, homeowners have the opportunity to reduce their energy expenses and improve their living conditions.
- **Smart Data Analytics** – AI-driven data can assist consumers in determining their energy consumption, so enabling them to make informed decisions regarding enhancing their homes' energy efficiency.
- **Improved Home Comfort** – Automatic climate control adjusts the temperature and humidity based on the

weather, making rooms warmer and more comfortable while reducing energy use.

- **Integration with Smart Grid** – The most efficient distribution of energy can be achieved by regulating demand during both peak and off-peak hours and utilizing sophisticated infrastructure.

4. HARDWARE NODE MCU

Free and open-source NodeMCU connects devices online. Examples include the Wi-Fi module. A 32-bit Tensilica Xtensa L106 CPU has a low-noise receiver, amplifiers, filters, and power management modules. Lua is used.

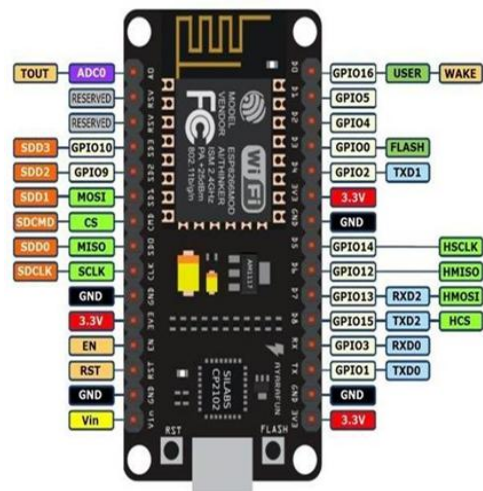

Fig 1: Node MCU Advantages of NodeMCU

1. Low power consumption.
2. Inbuilt Wi-Fi module
3. Low cost.

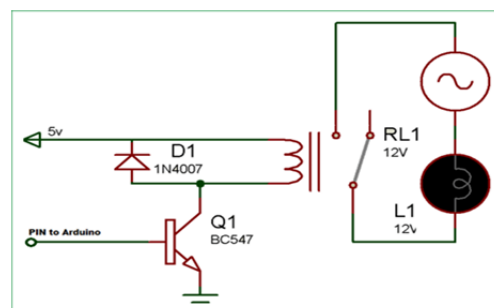

Fig 2: Relay



5. SOFTWARE

Google assistant

Software that uses Google's artificial intelligence can be used to construct a fake voice assistant. In reaction to your vocalizations, it makes noises. Because of this, a mobile device becomes much more useful and easy to use. Just say "Ok Google" to start it up.

Home appliances can be controlled and communicated with remotely using this software.



Fig 3: Virtual Assistant

Blynk

The program has the capacity to operate phones and manage devices through Wi-Fi. Functions are controlled by the TCP/IP protocol. A wide range of Internet of Things (IoT) tasks can be accomplished with the software. For our project, this program will generate virtual switches that we may use to manage our household appliances.

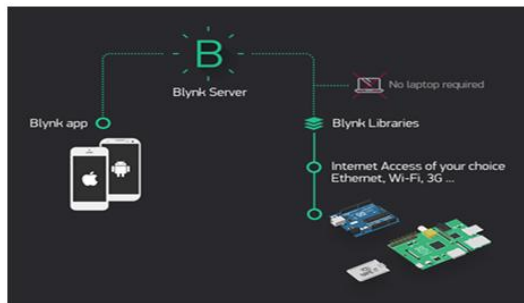

Fig 4: Blynk Server

Relay channel module

A wide variety of high-power devices rely on relays, which are valves. You can control it with a microcontroller. In order

to power the devices, the NodeMCU receives signals with high voltage and activates the inductor. Because it is completely unresponsive to even a mild electrical input, it stays in a state of dormancy.

Briefly, the term encapsulates the notion of "If This Then That." Because of this, the Blynk app and the Google Assistant can communicate with each other. Building an applet that lets Blynk and Google Assistant talk to each other is a top priority. Blynk can now respond to voice commands for controlling our home appliances thanks to this widget. All you need is a Google account to see this page and use Google Assistant.

Arduino IDE

The use of this tool to program Arduino-compatible circuits is made much easier. Three different programming languages are available: Java, C, and C++. Be sure to include the Blynk application registration code in the NodeMCU board code.

6. WORKING AND RESULT

Google Assistant can be used to operate household appliances with voice commands transmitted over the NodeMCU once the prototype is built and all components are assembled. Linking the Blynk app to IFTTT makes this possible.

The main focus here is the IoT, or Internet of Things. Users are able to operate their appliances with voice commands thanks to this smart home automation system that uses NodeMCU. It saves energy and works well.

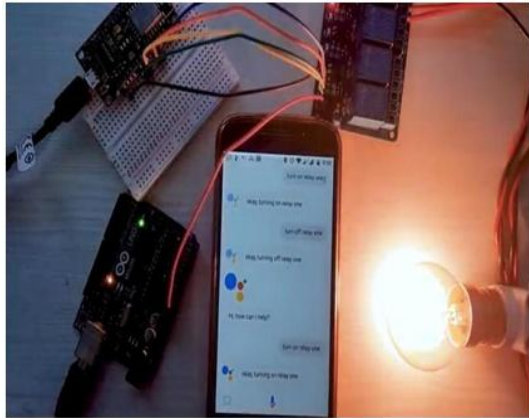

Fig 5: Working Connection

7. CONCLUSION

An IoT-based smart home management system is crucial for improving convenience, saving money, and optimizing energy usage. With the help of smart sensors, cloud computing, and AI-driven automation, the system can keep tabs on and manage all of your home appliances in real time. Efficient energy consumption and little waste are achieved through capabilities including remote access, automatic scheduling, and predictive maintenance.

The Internet of Things streamlines home management, enhances the user experience, and allows for seamless device communication. The approach would be supported by environmentalists due to its emphasis on renewable energy sources and its reduction of carbon emissions. Smart grids allow for consumption of energy based on demand, which allows for quick improvements to the power system. Modern security innovations, such as smart locks and remote monitoring, greatly improve the protection of homes. Internet of Things (IoT) home control systems of the future will be smarter, more useful, and less harmful to the environment.

FUTURE SCOPE:

The smart grid, big data analytics, and AI have all made great strides recently, which bodes well for the possibility of an IoT-based, energy-efficient house control system. Home automation systems that utilize the Internet of Things (IoT) will use machine learning to decrease electricity consumption, in response to widespread environmental concerns. Appliances in the house will soon be able to learn from their users' habits, weather patterns, and energy usage levels thanks to self-learning technology. Energy waste and power costs can be significantly reduced with improved operational efficiency.

Smart home automation will become more dependable and efficient as 5G connectivity and edge computation continue to develop. By streamlining the integration of all IoT devices, automated solutions will improve future safety. A few examples of how they'll improve things are lighting, ventilation, and temperature control. One way to make homes more eco-friendly is to install renewable energy sources like solar panels and smart grids. Potentially more efficient energy generation, storage, and use might be made possible by these technological advancements. Cyberattacks on IoT-enabled smart homes must be prevented by implementing blockchain technology and improving security mechanisms to safeguard user privacy and guarantee system performance.

REFERENCES

1. Pathare, A. A., & Sethi, D. (2024). Development of IoT-enabled solutions for renewable energy generation and net-metering control for efficient smart



- home. Discover Internet of Things, 4(1), 11.
2. Pawar, S. B., Abrol, P., Mishra, A., & Adgurwar, S. (2024). Solar empowerment: A critical review of intelligent home automation technologies. *Journal of Nuclear Engineering & Technology*, 14(1), 25–31.
 3. Oseiwe, S., & Ajadalu, A. (2024). Optimizing energy efficiency in smart home automation through reinforcement learning and IoT. *Asian Journal of Research in Computer Science*, 17(11), 9–24.
 4. Abbas, H., Ajaz, N. S., Jayaram, N., Thara, S., & Thomas, T. (2024). Energy management system with home automation. *Journal of Energy, Environment & Carbon Credits*, 14(1), 1–10.
 5. Garg, Q., Tang, S., Hao, J., Di Sarno, L., Wu, G., & Ren, S. (2023). Building automation systems for energy and comfort management in green buildings: a critical review and future directions. *Renewable and Sustainable Energy Reviews*, 179, 113301.
 6. Kalogridis, G., Efthymiou, C., Denic, S. Z., Lewis, T. A., & Cepin, M. (2021). Privacy for smart meters: Towards undetectable appliance load signatures. In *Proceedings of the First IEEE International Conference on Smart Grid Communications* (pp. 232–237).
 7. Sou, K. C., Weimer, J., Sandberg, H., & Johansson, K. H. (2021). Scheduling smart home appliances using mixed integer linear programming. In *Proceedings of the 50th IEEE Conference on Decision and Control and European Control Conference (CDC-ECC)* (pp. 5144–5149).
 8. Lee, Y. T., Hsiao, W. H., Huang, C. M., & Chou, S. C. T. (2021). An integrated cloud-based smart home management system with community hierarchy. *IEEE Transactions on Consumer Electronics*, 62(1), 1–9.
 9. Kim, D. S., Son, S. Y., & Lee, J. (2020). Developments of the in-home display systems for residential energy monitoring. *IEEE Transactions on Consumer Electronics*, 59(3), 492–498.
 10. Son, Y. S., Pulkkinen, T., Moon, K. D., & Kim, C. (2020). Home energy management system based on power line communication. *IEEE Transactions on Consumer Electronics*, 56(3), 1380–1386.
 11. Kushiro, N., Suzuki, S., Nakata, M., Takahara, H., & Inoue, M. (2020). Integrated residential gateway controller for home energy management system. *IEEE Transactions on Consumer Electronics*, 49(3), 629–636.
 12. Hernandez, S., Romero, R., & Giral, D. (2020). Optimization of the use of residential lighting with neural network. In *International Conference on Computational Intelligence and Software Engineering (CiSE)* (pp. 1–5).
 13. Han, J., Choi, C. S., Park, W. K., & Lee, I. (2020). Green home energy management system through comparison of energy usage between the same kinds of home appliances. *IEEE Transactions on Consumer Electronics*, 59(3), 402–408.



-
14. Ramlee, R. A., Leong, M. C., & Ismail, M. A. (2020). Design and development of home automation system. In *Proceedings of the 2013 International Conference on Electrical, Electronics and System Engineering (ICEESE)* (pp. 43–48).
 15. Shakeri, M., Shayestegan, M., Abunima, H., Reza, S. S., Akhtaruzzaman, M., Alamoud, A. R. M., & Amin, N. (2020). An intelligent system architecture in home energy management systems (HEMS) for efficient demand response in smart grid. *Energy and Buildings*, 138, 154–164.
 16. Kumar, N. M., & Kumar, J. S. (2020). Internet of Things based smart energy management: A survey. *International Journal of Applied Engineering Research*, 15(1), 1–8.